



# MGC Health Bath Chair with Armrest & Back Rest in Microban

POWERED BY  
**MICROBAN**®

**MGC HEALTH Bath Chair with Armrest & Back Rest with MICROBAN antimicrobial and antifungal technology is a must-have bathroom aid accessory to prevent slips and falls in the shower or a bathtub. This Bath Chair provides a safe bathing experience for people who have trouble standing and walking. MGC Health Bath Chair ensures a stable place for patient to sit on when showering. MGC Health Bath Safety products provide you with best value for your money. We place great importance on the quality and usability of our Bath Safety Product Items. They are produced for MGC HEALTH at high-quality manufacturing facilities, they passed rigorous safety and durability testing by Bureau Veritas, & each shipment has been inspected by SGS. All MGC Health products come with a limited lifetime warranty.**

## Key Product Features

1. Protected by MICROBAN Antimicrobial & Antifungal Technology that helps prevent the growth of damaging stains and odor-causing bacteria on the product
2. Strongly Built with durable and corrosion proof Aluminum frame withholds a Weight Capacity of 350 lb with Height adjustable legs and seat height can be adjusted from 16 inch to 22 inch
3. Provides comfort & safe experience while bathing and helps seniors, elderly, disabled and people recovering from injury
4. Convenient for people lacking strength, stamina and people who are in pain & helps patient maintain independence
5. Safe in the bathtub with non slip rubber feet that firmly hold the seat in place and makes it easier for seniors to use and prevent from slipping while bathing.
6. Tool-free assembly makes it remarkably easy for seniors to assemble the Bath Chair by themselves.
7. The back rest and arm rest can be removed according to their preference









## Product & Packaging Specification

Specification	Description
UPC	383173000818
MGC Ref	IT000049
Material	HDPE, Aluminum
Seat Dimensions	13.5" W x 16" H
Seat Height	16" - 22"
Product Weight	8.8 lbs
Weight Capacity	350 lbs
Warranty	Limited Lifetime
Retail Box Shelf dimensions	24.4 x 22 x 16.7
Shipping Dimensions	25 x 23 x 16.5
Units per Case	4
Cases per pallet	34

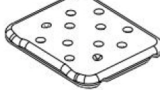
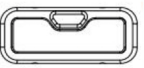
## Assembly Instruction

- A. Bench 1
- B. Backrest 1
- C. Aluminum Main Frames 2
- D. Aluminum Extension Legs 4
- E. Aluminum Backrest Frames 2
- F. Padded Arm Rest 2
- G. Long Hand Screws 4,  
Short Hand Screws 5
- H. Curved Washer 1

### IT000049

Hardware List				
	<b>A : 1PCS</b> 	<b>B : 1PCS</b> 	<b>C : 2PCS</b> 	<b>D : 1PCS</b> T-handle M6X35 
	<b>E : 2PCS</b> 	<b>F : 2PCS</b> 	<b>G : 4PCS</b> T-handle M6X37 	<b>H : 4PCS</b> T-handle M6X60 

1. instal  
back

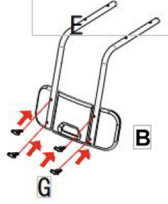

2. install  
palte

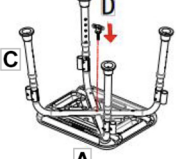

3.install  
rack

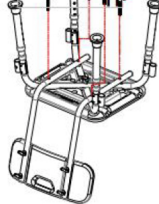

4.install  
handrail

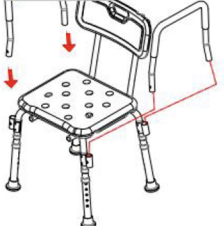

5.complete

